

## Traditional & Technology Infused Foldables for the Foreign Language Classroom

My Website:

[www.profehanson.weebly.com](http://www.profehanson.weebly.com)

My Email Address:

[hanson.desiree@gmail.com](mailto:hanson.desiree@gmail.com)

Traditional Foldables:

[www.dinah.com](http://www.dinah.com)

Technology Infused Foldables:

[www.printcutfold.com](http://www.printcutfold.com)



### IDEAS FOR IMPLEMENTING TRADITIONAL & TECHNOLOGY INFUSED FOLDABLES IN THE LOTE CLASSROOM

Find many examples of the below ideas at [profehanson.weebly.com](http://profehanson.weebly.com)

#### **Study Cards (Notecards)**

**Speaking Activities:** Teacher creates notecards with various clipart and then prints, cuts and places them in the holder. Create a set of notecards for every pair of students. Students use these notecards to guide them in speaking in the target language.

*A Few Examples:*

- **My Backpack** - clipart of backpack with different school supplies. Students each take a card and ask each other in the target language "What do you have in your backpack?" Students respond "I have \_\_\_\_\_, \_\_\_\_\_, etc. (see templates page for this activity)
- **Animals with Comparisons** – clipart of animals and cards with comparisons, students flip over two animals and a comparison card and formulate a sentence. Ex. El burro es más grande que el conejo. (see templates page for this activity)
- **Food/Meals** - clipart of different food on each card. Students ask each other in TL "What do you eat/What are you eating/What are you going to eat for breakfast/lunch/dinner?" Students respond using the pictures on the notecard to guide them. Could also use these cards to practice ordering at a restaurant or parts of recipe and one student gives commands while the other uses clipart to act out the instructions (Ex. Bate los huevos)
- **People** - clipart of a person on each card. Students can describe what person looks like and personality using adjectives, describe what person is wearing, can tell the person's profession, what she did/will do, what he/she likes to do, etc.
- **Places** – pictures of places, talk about where he/she will be going, went, etc.

**Grammar & Vocabulary:** Teacher creates notecards for students to practice grammar in a hands on experience. Can include clipart if desired. Print, cut and place the cards in the holder.

*A Few Examples:*

- **Verb Conjugations** - Students have to match the correct subject pronoun with the correctly conjugated verb, then students write the translation on a piece of paper or whiteboard. Ex. Match card: yo with card: ando (see templates pages for this activity)
- **Noun/Adjective agreement** - Students match the adjective to the noun. Ex. Match card: las casas with card: grandes
- **Definite and Indefinite Articles** - Students match the article to the correct noun. Ex. one card "el", another "muchacho", one card "las", another "cebollas", etc.
- **Vocabulary:** Create notecards with the word in the TL on one card and the other with a picture. Print on cardstock. Have students turn all cards facing downwards and play concentration in pairs.

List some of your ideas for **speaking, grammar & vocabulary activities** using **notecards**:

---

---

---

---

## Miniature Book Ideas

**Published Book:** Students create their own story and "publish" it either making a traditional minibook by writing and drawing pictures or by typing and adding clipart using the minibook template. First have students create their story on a piece of paper (see freewrite document on templates page). Give students about 15 minutes to write 100 words (see School Mini Book Steps on templates page to see the instructions I gave my students).

*A Few Examples:*

- **Reflexives:** Describe morning routine
- **Conditional:** If I were president/a movie star/rich, etc, I would...
- **Past:** Write about your favorite memory, create a mini fairytale, write baby book -info about your birth, physical appearance, personality and habits/routines when you were baby(see baby book instructions on templates page), do at beginning of year for higher levels – *What did you do this summer?* minibook
- **Grammar Book:** Great for reviewing a grammar point
- **Summarize:** Summarize a chapter or book in TL

**Days of the Week Book:** Have students write "Days of the Week" on front cover and then use the remaining 7 pages to include each day of the week, a weather expression and what they do that day. (See the instructions for days of week traditional minibook on the templates page)

**About Me Minibook:** yo soy (cover), pg 1. Nouns about you (4), pg 2. Adjectives about you (4), pg. 3 likes activities (me gusta) (4), pg 4 loves (me encanta) (4), pg 5 dislikes (no me gusta) (4), pg 6 soy de (lugar), pg 7 name and graphic design

List additional ideas for using **miniature books** in your classroom:

---

---

---

---

## Diorama Ideas

**Clothing:** Describe what people are wearing based on picture. (see template page for student instructions)

**Family:** Describe family based on picture using adjectives, how old they are, what they like to do, etc. (see template page for example)

**Simplified Day of the Dead Altar:** Students include a picture of a person who has passed away as well as pictures of typical things on an altar along with a description in the imperfect. (see template page for example)

**Wanted Criminal:** Students create a fictional wanted person and a funny crime and include physical appearance, what person was wearing when they were last seen, what crime the person committed, etc. (see template page for instructions and example)

**Dream Person:** Students include pictures and use subjunctive. "I want a person that is handsome, etc."

**Future Job:** Students use the future to talk about what they will be when they are older.

List additional ideas for using **dioramas** in your classroom:

---

---

---

---

## Cascading Flip Book Ideas

**Grammar:** Students create their own flip book focusing on grammar. It can be on a single grammar point (subjunctive, preterite, etc.) or students can use the dual flipbook to compare two things (ser vs. estar, por vs. para, preterite vs. imperfect, two ways to say "to know") (see template page for examples). If traditional, students can keep adding notes to flipbook as you teach more store in binder for reference (ex. preterite regular and irregular conjugations, imperfect regular and irregular conjugations, preterite uses, imperfect uses)

**End of Semester/Year Grammar Review:** A great quick reference with important details about each grammar point that not only prepares them for the final but also they can use the following semester, year, etc. Students create their own flip book with each tab having a different grammar point. Students explain a different grammar point on each flap. Students can three hole punch their flip book and store it in their binder for future reference and to keep for the following year. (see website for instructions)

List additional ideas for using **cascading flip books** in your classroom:

---

---

---

---

## Pyramid Ideas

**¿Cómo quieres que sea tu vida?:** Students use present subjunctive and indicative to express hopes for the future. They use each use of the Subjunctive (WEIRDO) including pictures and sentences about their future. They create 2 pyramids – each rule gets its own side. (see template and student example on my website)

**Preterite & Imperfect:** Students write a 6 specific events in past with pictures on one side, 5 general statements about past with pics on another, and a paragraph about grandparents past using both preterite and imperfect along with a picture. (template and student example on website)

**Comparatives/ Superlatives:** (good, better, best) (see template page for example)

**Verb Endings:** Compare endings for -ar, -er, -ir verbs in a tense

**Past/Present/Future:** Compare/Contrasts the formation of these tenses

**Stem Changing Verbs:** (see template page for example)

**Record story in target language:** Write the beginning, middle and end of a story

**Sometimes/Always/Never:** Write sentences with these adverbs of frequency

**What you Eat:** Write sentences with what you like to eat for breakfast/lunch/dinner

**Art:** On one side include a drawing from the artist, on second side discuss the features of the artwork or the artist and the third side draw own drawing representing own life using the art style the artist uses (realism, surrealism, etc.).

List additional ideas for using **pyramids** in your classroom:

---

---

---

---

**The following pages in this packet are from:**

Basic Shapes, Layered Book Foldable Directions and Pyramid Foldable Directions are from [Dinah Zike's Foldables](#)

Four Door Diorama is from [Dinah Zike's High School World History and Reading and Study Skills Foldables](#)

Folding a Mini Book is from Half Hollow Hills website

[http://www.halfhollowhills.k12.ny.us/uploaded/SummerSchool/folding\\_mini-book.pdf](http://www.halfhollowhills.k12.ny.us/uploaded/SummerSchool/folding_mini-book.pdf)

# Basic Shapes

by Dinah Zike

These figures illustrate the basic folds that are referred to throughout the following section of this book.

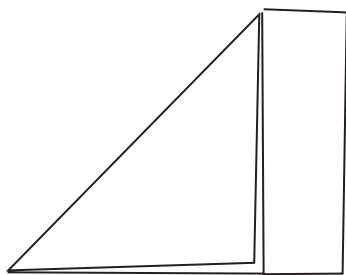

**Taco Fold**

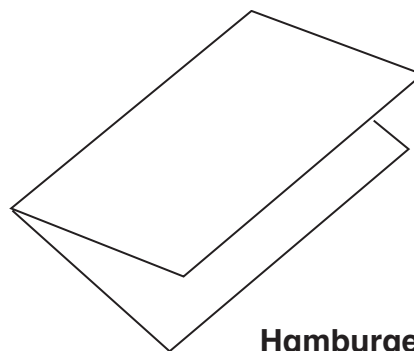

**Hamburger Fold**

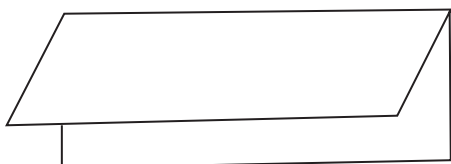

**Hot Dog Fold**

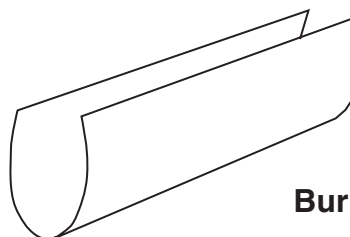

**Burrito Fold**

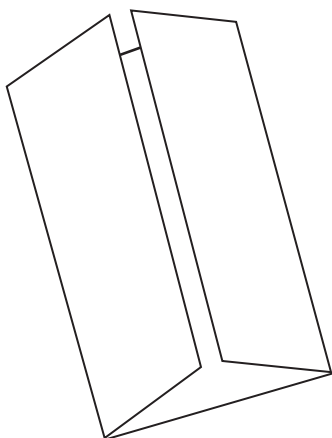

**Shutter Fold**

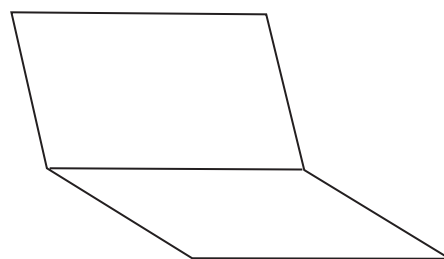

**Valley Fold**

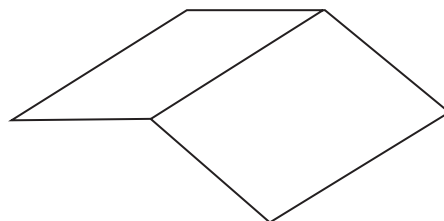

**Mountain Fold**

# Layered Book Foldable™ Directions

by Dinah Zike

## Materials:

- two sheets of 8½" × 11" paper
- glue

## Directions:

1. Stack two sheets of paper so that the back sheet is one inch higher than the front sheet.

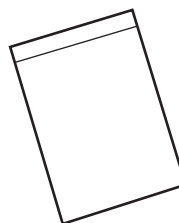

2. Bring the bottom of both sheets upward and align the edges so that all of the layers or tabs are the same distance apart.



3. When all tabs are an equal distance apart, fold the papers and crease well.

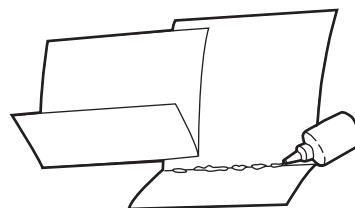

4. Open the papers and glue them together along the valley, or inner center fold, or staple them along the mountain.

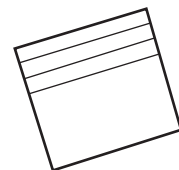

**Tip!** *If you need more layers, use additional sheets of paper. Make the tabs smaller than one inch.*

Use this Foldable to \_\_\_\_\_

# Pyramid Foldable™ Directions

by Dinah Zike

## Materials:

- one 8½" × 11" sheet of paper
- scissors
- glue

## Directions:

1. Fold the sheet into a taco. Cut off the excess rectangular tab formed by the fold.

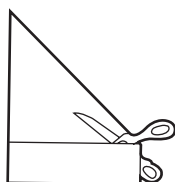

2. Open the folded taco and refold it like a taco the opposite way to create an X-fold.

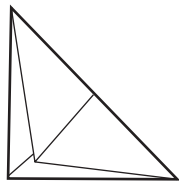

3. Cut one of the valleys to the center of the X, or the midpoint, and stop. This forms two triangular flaps.

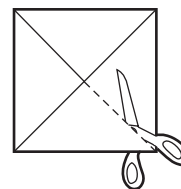

4. Glue one of the flaps under the other, forming a pyramid.

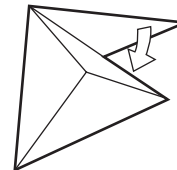

Use this Foldable to \_\_\_\_\_

---

---

---

---

---

---

---

---

---

## Four-Door Diorama

1. Make a *four-door book* out of a *shutter fold*.
2. Fold the two inside corners back to the outer edges (*mountains*) of the *shutter fold*. This will result in two *tacos* that will make the *four-door book* look like it has a shirt collar. Do the same thing to the bottom of the *four-door book*. When finished, four small triangular *tacos* have been made.
3. Form a 90-degree angle and overlap the folded triangles to make a display case that doesn't use staples or glue. (It can be collapsed for storage.)
4. Or, as illustrated, cut off all four triangles, or *tacos*. Staple or glue the sides.

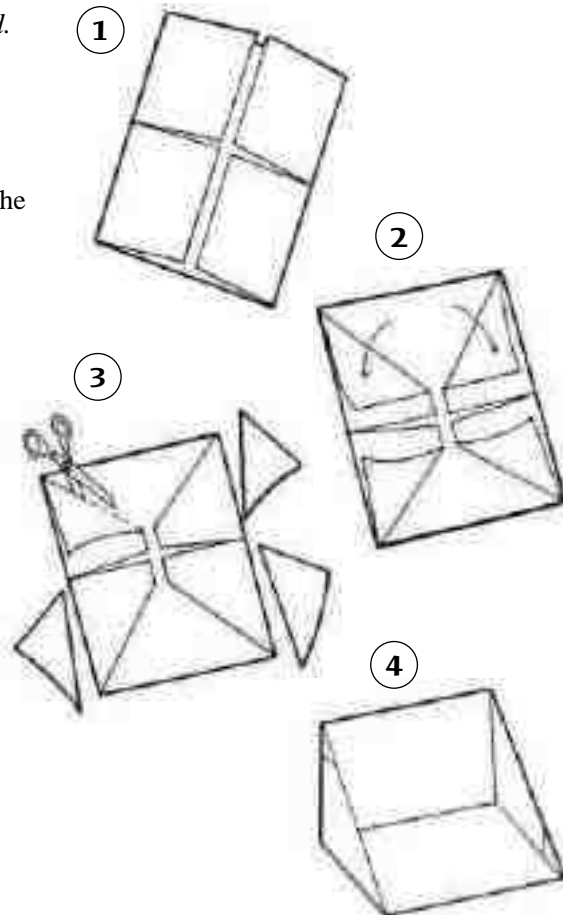

Glue display cases end-to-end to compare and contrast or to sequence events or data.

Use 11" x 17" paper to make a large display case.

Use poster board to make giant display cases.



# Folding a Mini Book

1. Hold the paper portrait view and fold it in half lengthwise, then open it out again.

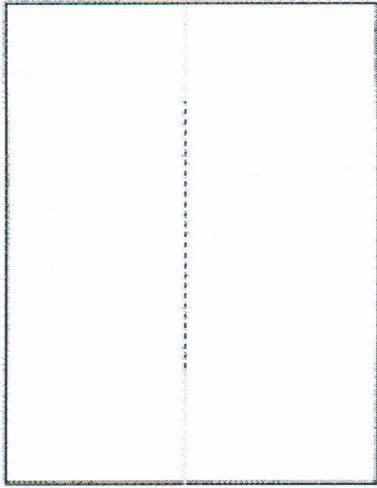

2. Hold the paper landscape view and fold it in half lengthwise. Fold each half backwards one more time to form four equal sections. unfold the paper up to where you have two halves.

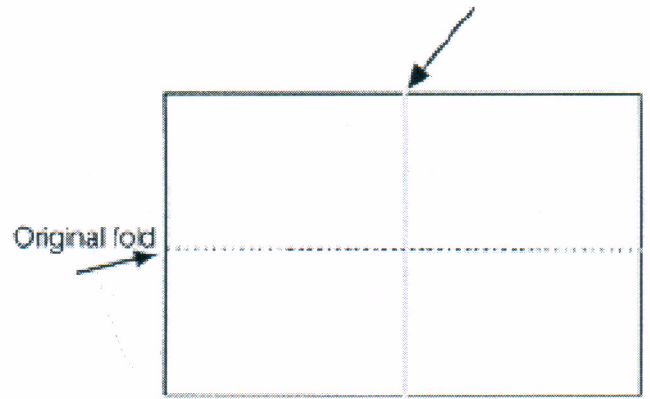

3. Fold each half backwards one more time to form four equal sections. Unfold the paper up to where you have two halves.

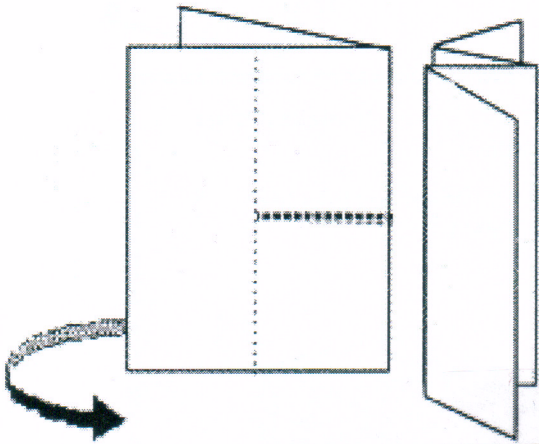

4. Cut the paper along the horizontal dotted line.

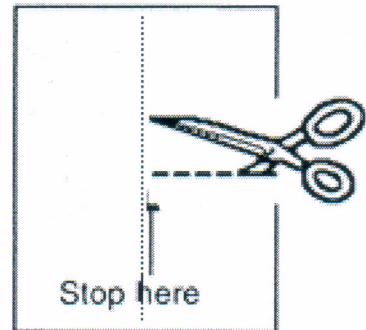

5. Grab with forefingers and pull down on each side,

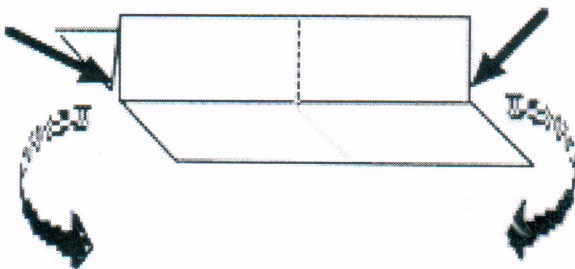

hold on to to both ends and push in as shown in the picture below. When the folding is completed, make sure that all the pages are in the correct order.

